

eIC52MS

CEILING LOUDSPEAKERS

Marine / Sauna In-Ceiling Loudspeaker



PRODUCT OVERVIEW

ECLER ESSENTIALS eIC52MS is a 2 way cost-effective in-ceiling loudspeaker with a great sound performance, suitable for installations exposed to extreme humidity and/or temperature. It features a 5" woofer and a 1" tweeter, 20 WRMS @ 8 ohm nominal power.

KEY FEATURES

- Two-way speaker, 5" woofer + 1" tweeter
- 20 WRMS
- Faston male input terminals: 4.8mm (+) and 2.8mm (-)
- Suitable for installations exposed to extreme humidity and/or temperature
- EASE Win file available 

APPLICATIONS

- Saunas
- Spas
- Aquariums
- Ships
- Harbours

TECHNICAL DATA

Nominal low impedance	8Ω
RMS power	20 WRMS
Max power	40 W
Frequency response (-10 dB)*	80Hz – 20kHz
Sensitivity 1W/1m*	89 dB
Heat resistance test (48h)	70 ± 2°C, 20 ~ 25 %
Humidity resistance test (48h)	40 ± 2°C, 90 ~ 95 %
Cold resistance test (48h)	-25 ± 2°C
External diameter	165 mm
Internal diameter	120 mm
Required depth	79 mm
Weight	0,70 kg

*After resistance tests

MECHANICAL DIAGRAMS

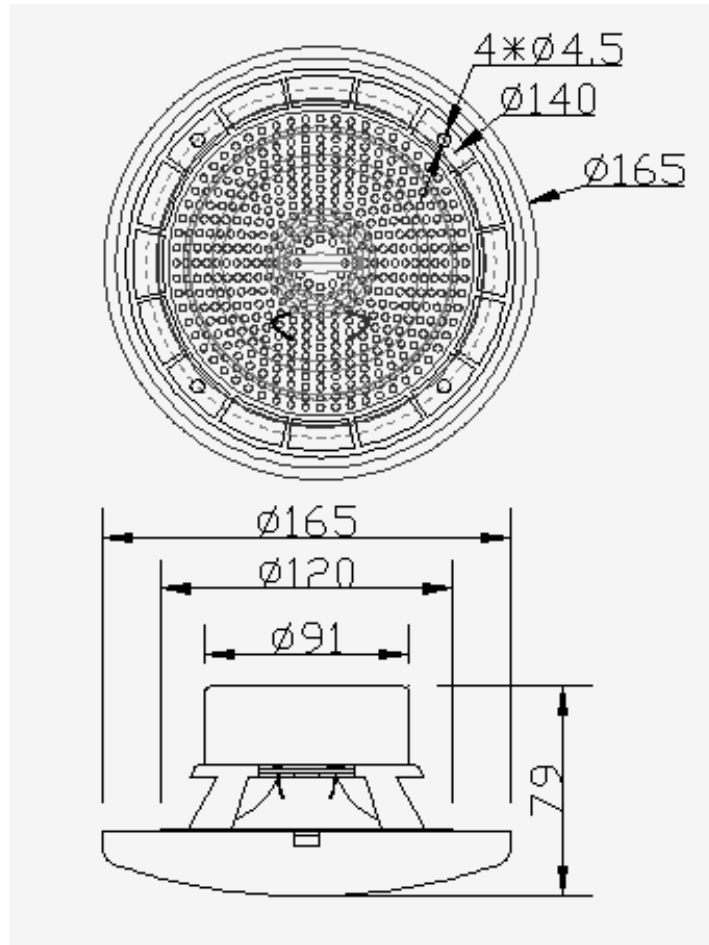

FREQUENCY RESPONSE

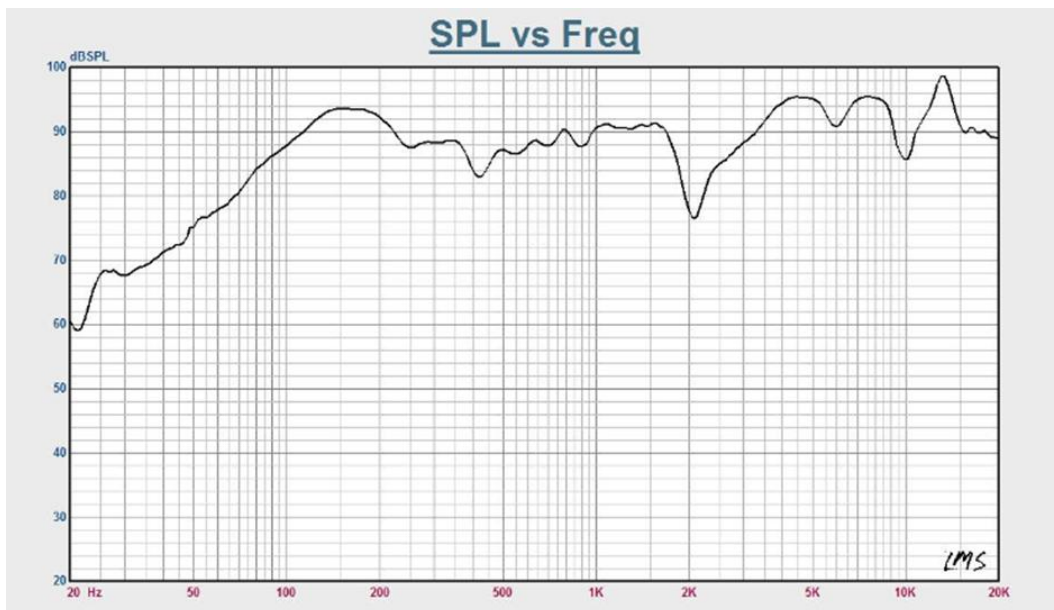

POLAR DIAGRAMS

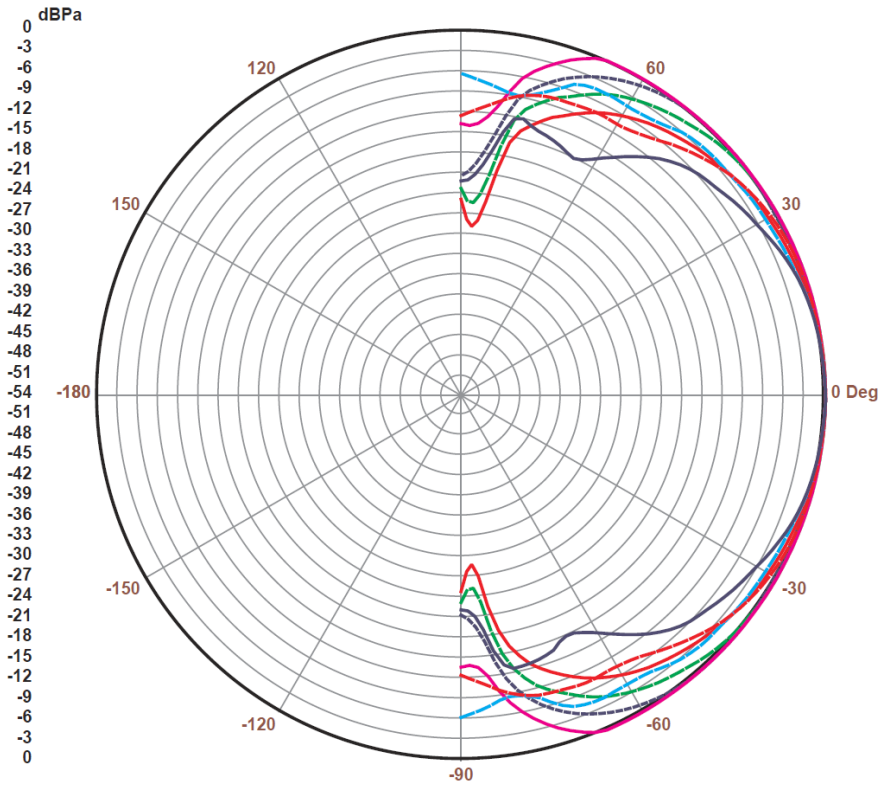

Curve	Freq	BW	Q	DI
—	125.00	115	3.1	5.0
—	250.00	133	2.7	4.3
—	500.00	147	2.4	3.9
—	1.00K	155	2.3	3.7
—	2.00K	142	2.5	4.0
—	4.00K	100	3.6	5.6
—	8.00K	84	4.3	6.3